

ISP Outline Dimensions

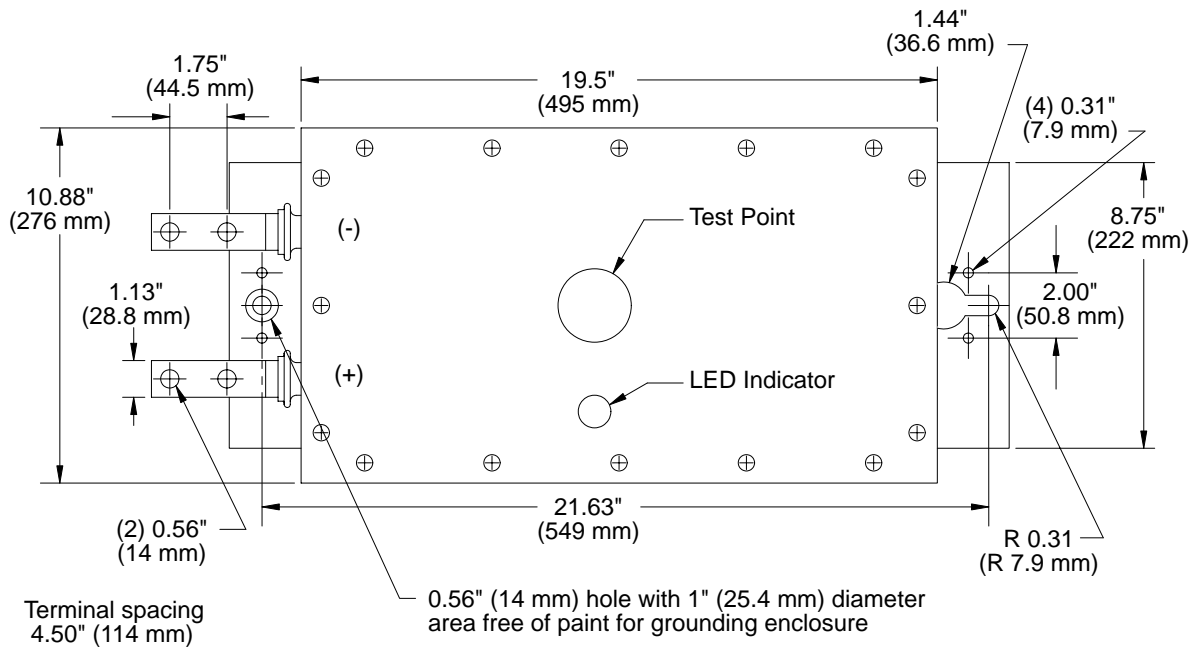

Terminal spacing  
4.50" (114 mm)

Polarity marks (shown above) are embossed on end of enclosure above each terminal

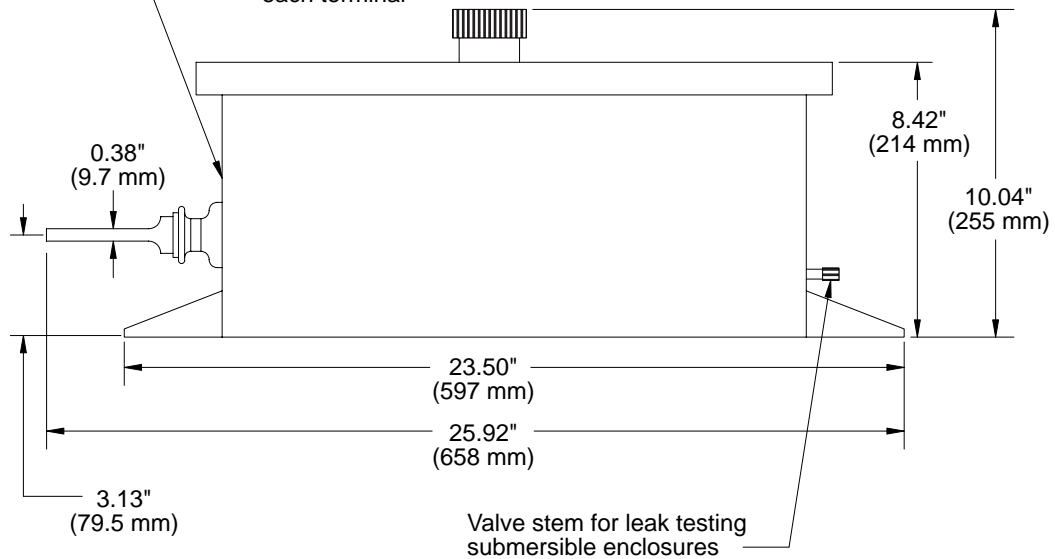

Notes:

1. Test Point: An option only provided when specified.
2. The Test Point and LED indicator are only available with a non-submersible enclosure.

Applicable to:

ISP with "C" Code in Model # = 7 (60Hz) or 6.7(50Hz)

ISP Outline Dimensions

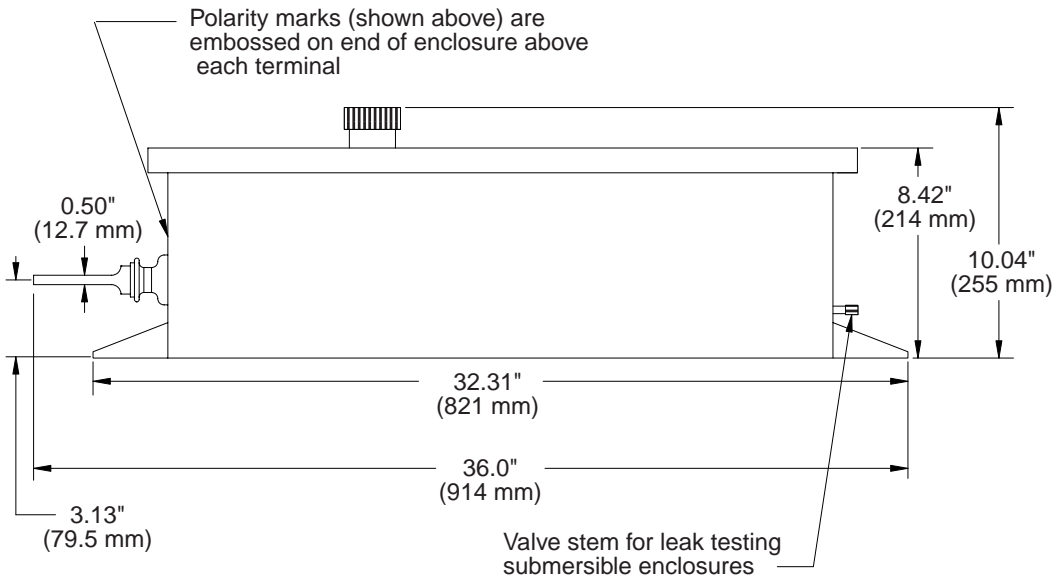
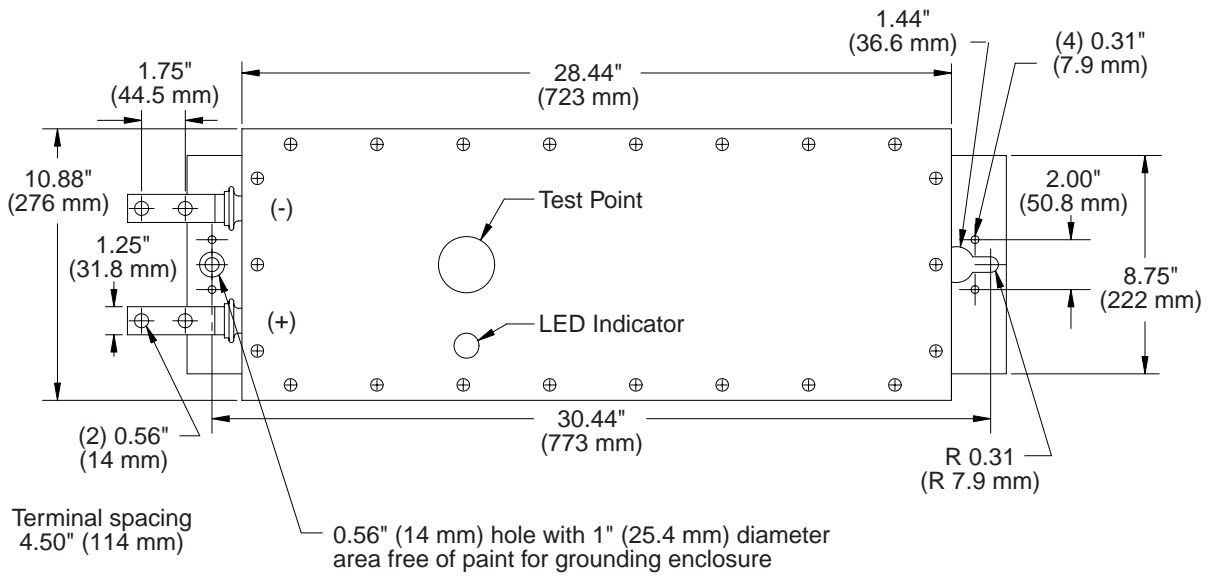

Notes:

1. Test Point: An option only provided when specified.
2. The Test Point and LED indicator are only available with a non-submersible enclosure.

Applicable to:

ISP with "C" Code in Model # = 24, 35, or 68A (60Hz)

ISP with "C" Code in Model # = 23, 33, or 65A (50Hz)